

# HA020/010L



# HA020, HA010L

## Manipulator Specifications

Item		Specification	
Model		HA020	HA010L
Construction		Articulated	
Payload		20Kg	10Kg
Max. Reach		1,765mm	1,986mm
Degree of freedom		6	
Installation		Floor/Wall/Ceiling	
Max. Working Envelope	Arm	S Swivel	±180°
		H For/Backward	+150° ~ -110°
		V Up/Downward	+250° ~ -155°
	Wrist	R2 Rotation 2	±180°
		B Bending	±135°
Max. Speed	Arm	R1 Rotation 1	±360°
		S Swivel	170°/s
		H For/Backward	165°/s
	Wrist	V Up/Downward	170°/s
		R2 Rotation 2	335°/s
Wrist Torque	B Bending	R1 Rotation 1	600°/s
		R2 Rotation 2	4Kgf·m
	R1 Rotation 1	B Bending	4Kgf·m
		R2 Rotation 2	2Kgf·m
Accuracy of position repeatability		±0.08mm	
Ambient Temperature		0 ~ 45°C (273~318K)	
Relative Humidity		20 ~ 85%RH	
Weight		240Kg	245Kg
Working Envelope Section area		5.58m <sup>2</sup>	7.22m <sup>2</sup>

### Working Envelope

HA020

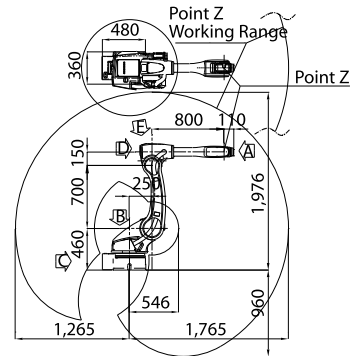

HA010L

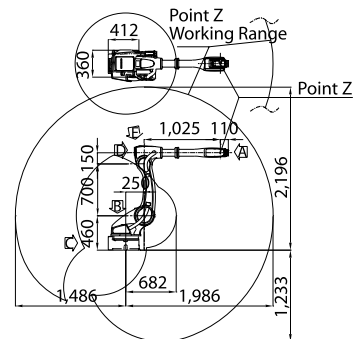

### View "A" For Tool Attachment

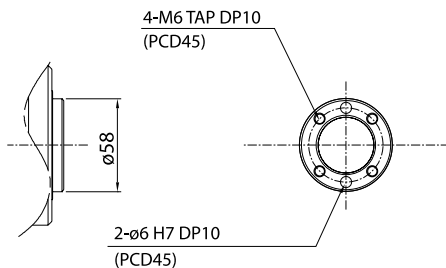

### View "B" For Installation

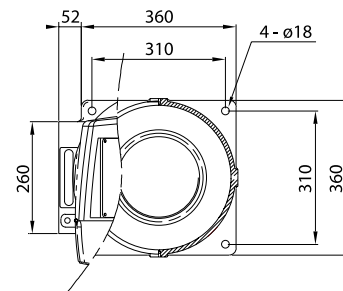

### View "C" For User Application

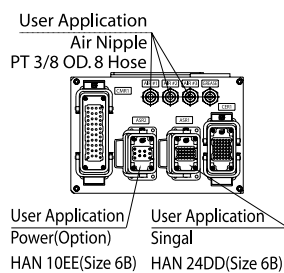

### View "D" For User Application (Option)

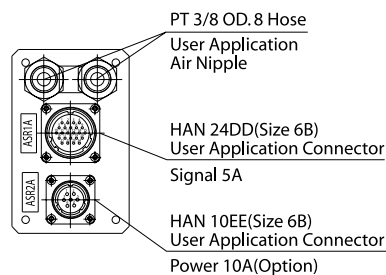

### View "E" For Cable Guide

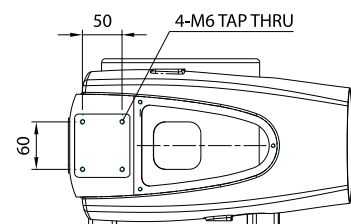

## ■ Controller Specifications

Item	Specification
Type	Hi4a
Microprocessor Technology	32 bits RISC CPU
Program Execution Mode	Teaching & Playback
Operation Mode	Menu-Driven & Code input
Interpolation Type	Linear, Circular
Memory Back-up Type	Battery back-up IC memory
Encoder Type	Serial Absolute encoder
Servo Drive Unit	6 Axes/unit, digital servo
Maximum Axes	12 Axes Max. Simultaneously
Step	10,000 Points
Program Selection	255(Binary)/8(Discrete)
Teach Pendant Display Spec.	LCD(40X15), Backlight 57,600 baud rates, 3 Position Enable Switch
Digital I/O	Input : 32 points (160 points Max.) Output : 32 points (160Points Max.)
Analog I/O	Input : 4 Points (Option) Output : 4 Points (Option)
Conveyor Pulse Counter	Line Driver / Voltage Output (Option)
Serial Port	RS232C : 2 Ports (1Port : Option)
Communication Function (Option)	DeviceNet, Profibus-DP, Ethernet, CC-Link
PC Card Function	PCMCIA (IC card : Option)
Rated (Supply) Voltage	3-phase 220V (50/60Hz)±10%
Max. Rated Power	5.5KVA
Dimension (WxHxD)	675mm x 1,190mm x 675mm
Weight (Without Transformer)	205Kg
Protection Classification	IP54
Ambient Temperature	0~45℃
Ambient Humidity	Normal 75%

- Easy and Simple Operation
- Powerful Robot Language
- Easy Maintenance
  - Displaying cause of errors and troubleshooting
- Safety
- Compatibility and Connectivity
  - Embedded PLC
  - FieldBus : DeviceNet, Profibus-DP, CC-link
  - Easy I/O board expansion :  
Connecting I/O master through Computer
- Compact Size Controller
  - Default space for 2 additional axis amp

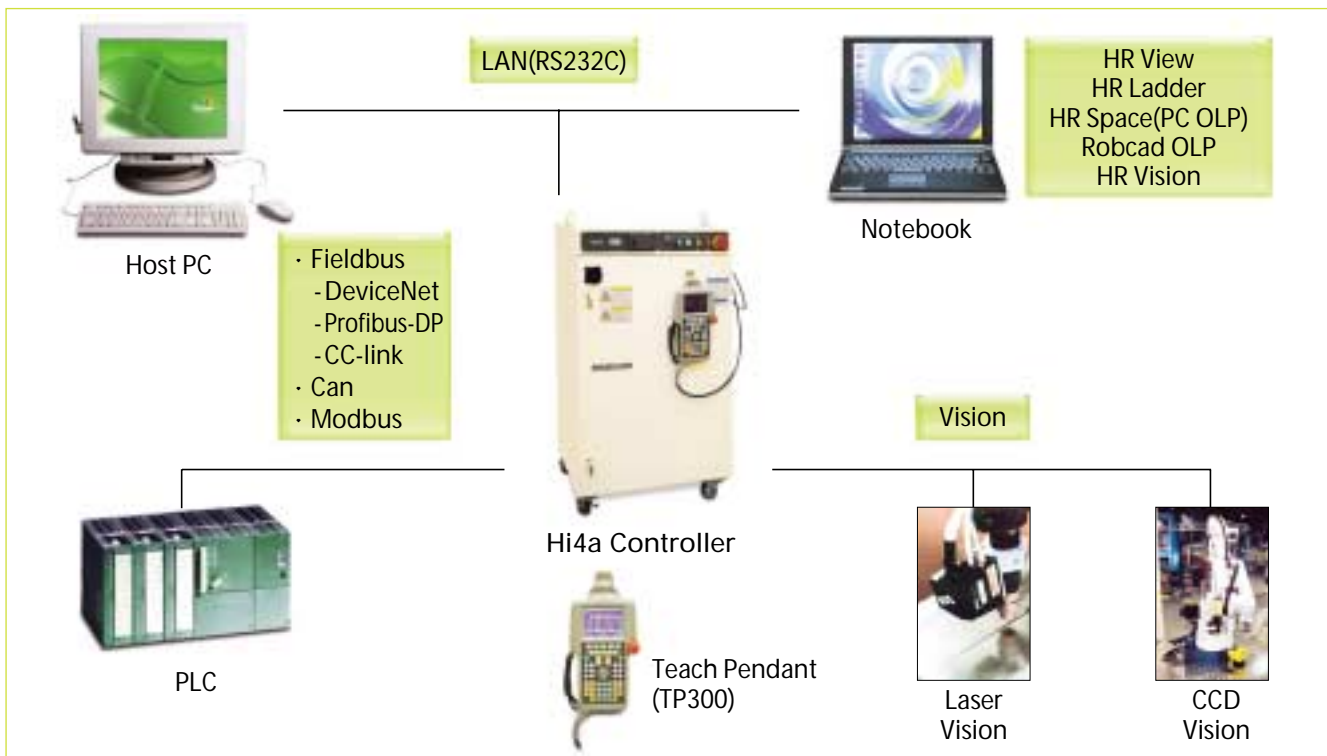



### Key Features

- Enlargement of working envelope by serial link structure
- Improvement of dynamic performance



### Application

- Arc welding
- Sealing
- Cutting
- Assembly



### ■ Certificate (UL, CSA, CE, ISO, QS) ■



#### Head Office

1, Jeonha-dong, Dong-gu, Ulsan, Korea  
TEL : 82-52-230-7901 / FAX : 82-52-230-7900

#### Seoul Office

140-2, Gye-dong, Jongno-gu, Seoul, Korea  
TEL : 82-2-746-4711 / FAX : 82-2-746-4720

#### Ansan Office

1431-2, Sa-dong, Sangnok-gu, Ansan-si,  
Gyeonggi-do, Korea  
TEL : 82-31-409-4945 / FAX : 82-31-409-4946

#### Cheonan Office

355-15, Daga-dong, Cheonan-si,  
Chungcheongnam-do, Korea  
TEL : 82-41-576-4294 / FAX : 82-41-576-4296

#### Daegu Office

223-5, Beomeo 2-dong, Suseong-gu, Daegu, Korea  
TEL : 82-53-746-6232 / FAX : 82-53-746-6231

#### Gwangju Office

415-2, Nongseong-dong, Seo-gu, Gwangju, Korea  
TEL : 82-62-363-5272 / FAX : 82-62-363-5273